

POWERSTACK EPSC+

SPECIAL GAS VENT – DOUBLE WALL

TECHNICAL DATA & PARTS CATALOG

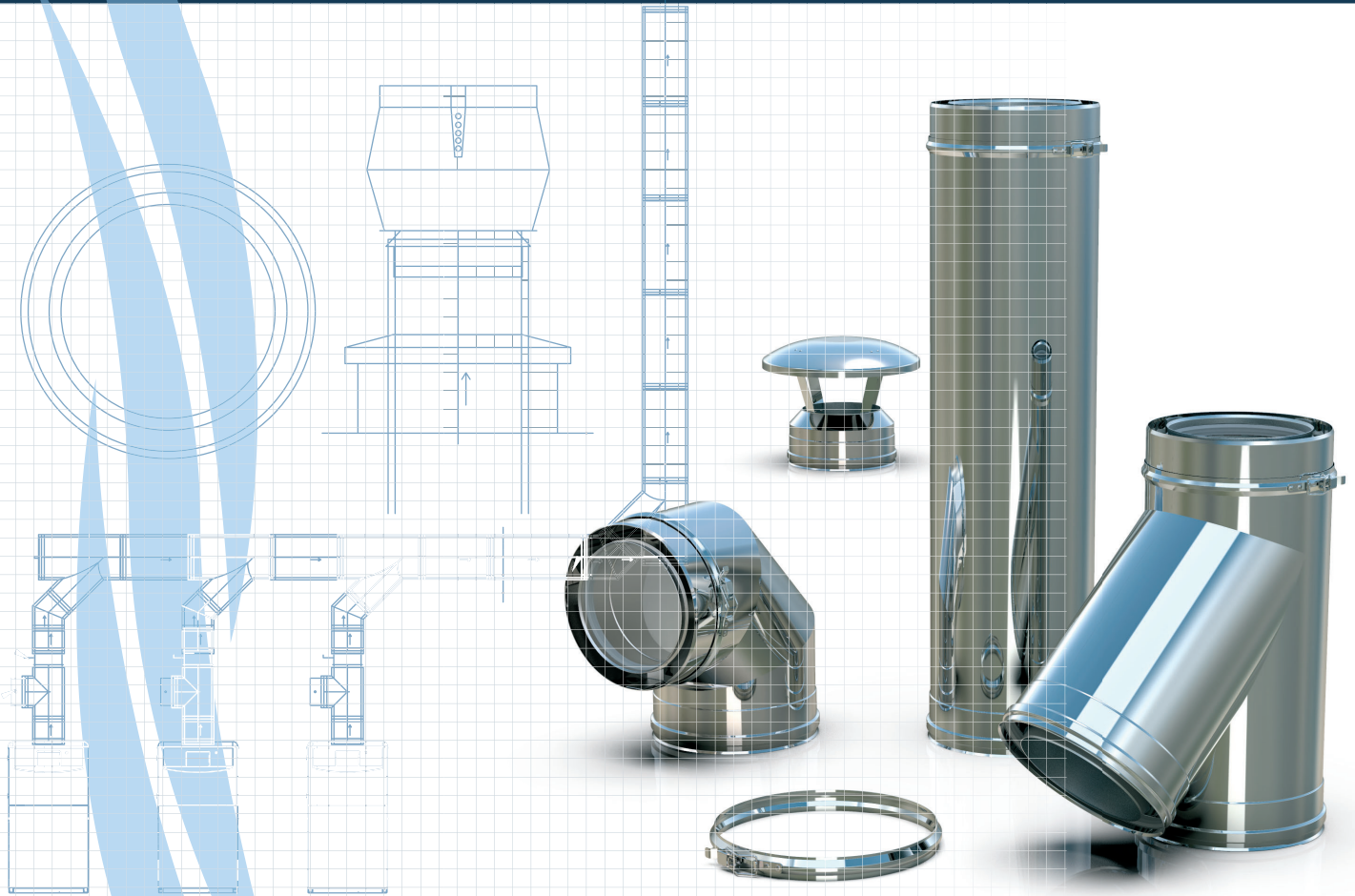

Simple. Seamless. Smart.

ENERVEX[®]
VENTING DESIGN SOLUTIONS





ENERVEX:

INNOVATIVE VENTING DESIGNS, ENGINEERED FOR SAVINGS

ENERVEX is a world-leading supplier of mechanical draft systems and integrated venting design solutions. We introduced the industry's first mechanical draft fan in 1958 and today deliver one-stop venting systems from boiler outlet to chimney termination. We serve customers in North and Central America as well as the Middle East from our 80,000+ sq. ft. facility in Atlanta, GA.

Every ENERVEX solution is evaluated and built from the ground up with careful evaluation of the unique cost variables and long-term financial savings for each customer. Through superior manufacturing technology and decades of experience, we're delivering high-quality, listed and certified venting solutions that are economical, environmentally sustainable, aesthetically pleasing, reliable, and code compliant. Backed by the best performance guarantee in the business.

Since the invention of the chimney fan, ENERVEX continues to bring industry-first innovation to market:

- Modulating mechanical draft systems (1991)
- Modulating combustion air supply systems (1995)
- True inline mechanical draft fans (2006)
- Inline flue gas economizer with modular heat exchanger systems (2013)
- Single universal chimney systems listed for virtually all venting applications (2015)
- High-temperature, pressure, and leak-resistant graphite gaskets for sealing fan & chimney joints (2015)
- Plume Abatement System for condensing boilers (2017)
- First manufacturer to offer fans with EC motors up to 30HP (2018)
- Patent pending Air to Air Heat Recovery system (2023)
- Integrating FEI and CO2 reduction calculations directly into WISP (2023)

ENERVEX designs and builds all of these products under a single, highly respected name and take full responsibility for operational excellence. That's our performance guarantee, and the reason why the ENERVEX brand has been trusted by some of the most successful projects in the world.

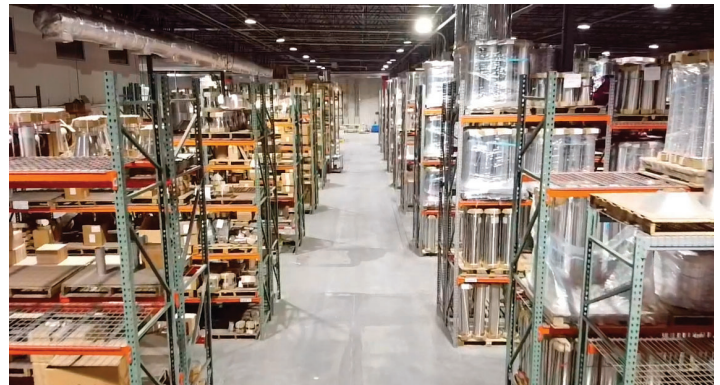

CONTENT

LISTINGS & CERTIFICATIONS

THE ULTIMATE VENTING SYSTEM

Listings and Certifications.....	5
Materials and Ratings.....	5
Assembly and Construction	5

SUPPORT DATA

Product Data.....	6
Clearances to Combustible for Special Gas Vent.....	6

JOINT ASSEMBLY PARTS

Standard Locking Band (LB)	7
HD Locking Band (TLB).....	7
Replacement Gasket (GG).....	7

STRAIGHT LENGTHS

Straight Lengths (SL).....	8
Adjustable Lengths (AL).....	9
Drain Section (DS).....	9
Tapered Increaser (TI)	10
Tapered Reducer (TR)	10
Eccentric Tapered Increaser (ETI).....	11
Eccentric Tapered Reducer (ETR).....	11

FITTINGS

90° and 87° Tee (T90 / T87)	12
45° Lateral Tee (T45)	13
90° and 87° Elbows (L90 / L87)	14
45° and 42° Elbow (L45 / L42)	14
30° Elbow (L30).....	15
15° Elbow (L15).....	15
6° Elbow (L6).....	16
3° Elbow (L3).....	16
Drain Tee Cap (DTC).....	17
Side Drain Tee Cap (DTCS)	17
Tee Cap (TC)	17

CONNECTIONS

Universal Boiler Adapter (UBA)	18
Appliance Connector Seal Ring (ACS)	18

TERMINATIONS

Rain Cap (RC)	19
Exit Cone (EXC).....	19
Miter Section (MS).....	20
Wall Terminal (WT)	20

SUPPORTS

Support Plate Assembly (SPA).....	21
Wall Support Assembly (WSA).....	21
Wall Guide (WG)	22
Floor Guide (FG).....	22
Full Ring / Half Ring (FR/HR).....	23
Guy Section Assembly (GSA)	23

PENETRATIONS

Roof Thimble (RT)	24
Wall Thimbles (WT).....	24
Flashings (FL)	25
Telescopic Flashing (TFL).....	25
Storm Collar (SC)	26
Fan Plate Adapter (FPA)	26

TRANSITIONS

Transition for TDF Power Venters (TTM/TTF).....	27
Transition from EPSC+ to EPSx (TCM/TCF).....	27

DAMPERS

Sealed Modulating Draft Damper (SMDS).....	28
Automatic Vent Damper (ADF).....	29
Balancing Baffle (BBF)	30
Barometric Draft Regulator (BDR).....	31

MECHANICAL DRAFT FANS

Inline Power Venter (TDF)	32
Chimney Termination Fan (RSV).....	33

WARRANTY

Standard 1-Year Warranty	36
Extended 15-Year Warranty.....	36

SELECTION GUIDE

GENERAL INFORMATION

The information in this catalog is provided to assist you with application information, codes and standards, dimensional information, support requirements and other data needed in conjunction with the use of ENERVEX's EPSC+ Special Gas Vent.

Unless otherwise indicated, all dimension are in inches (mm).

We will be happy to assist you with designing your project and can provide both design calculations and job-specific installation drawings in 2D and 3D.

For additional information you may contact us via:

Phone: +1 770-587-3238

email: info@enervex.com

Web: www.enervex.com

Complete information for proper and safe installation can be found in Powerstack Installation Instructions.

STANDARD AND LISTINGS

US:

NFPA 54	National Fuel Gas Code
NFPA 211	Standard for Chimneys, Fireplaces, Vents, and Solid-Fuel Burning Appliances
UL 378	Standard for Draft Equipment
UL 1738	Standard for Venting Systems for Gas-Burning Appliances, Categories II, III and IV.

CANADA:

B139	Installation Code for Oil Burning Equipment
B149	Natural Gas and Propane Installation Code
ULC/ ORD-C378	Standard for Draft Equipment
ULC-S636	Standard for BH Gas Venting Systems

PRODUCT CODES AND PART NUMBERS

All parts manufactured by ENERVEX are identified by numbers and letters that describe makeup and function. For example:

10EPSC+-T90

1. First two digits identify the component's internal diameter in inches. In this case the internal diameter is 10 inches.
2. The next four digits identify the type of vent (EPSC+)

Inner wall is always stainless steel 316L-PCM and outer casing is always stainless steel 304 (glossy)

3. Followed by a dash, finally the product's code Code is listed, such as T90 for a 90° Tee.

For products with reduction or increaser parts, the part number changes as follows:

For a 90° Tee with a 10" body and an 8" snout, the part number is

10EPSC+-8T90

For a tapered increaser with an 10" inlet and a 12" outlet, the part number is:

10EPSC+-12TI

LISTINGS & CERTIFICATIONS

The ENERVEX PowerStack EPSC+ venting system is Listed by Underwriters Laboratories, Inc. (UL) under UL File MH64314.

The EPSC+ is listed to UL 1738 Venting Systems for GasBurning Appliances, Categories II, III, and IV (480°F Vent Listing) / ULC S-636 Standard for Type BH Gas Venting Systems (480°F Venting Listing)

Under this category, EPSC+ in diameters 4" to 14" has been determined suitable for venting of flue gases at a temperature up to 480°F (249°C) from gas fired appliances. See Section 1.10 Clearances" for specific details

MATERIALS AND RATINGS

The PowerStack EPSC+ are made for residential, commercial and industrial applications. It is a factory made modular stainless steel venting system designed for quick assembly.

All parts have a male and female end with an Elastomer Triple Lip Seal.

The PowerStack is offered in a single wall version and is available in internal diameters ranging from 4" (100mm) to 14" (350mm). The fully welded liner is manufactured from a special corrosion resistant 316L PCM (Purified Chromium and Molybdenum).

A pressure capability of up to 15"Wg (3,745Pa) and condensate containment is achieved by using an Elastomer Triple Lip Seal as part of a simple push-fit joint design that is held in place with a lever type locking band.

All Powerstack models (EPS, EPSA, EPSC+, EPS1, EPS2, EPS3 and EPS4) may be intermixed in the same venting system, provided the proper associated airspace clearances-to-combustibles are maintained.

PowerStack EPSC+ is suitable for negative, neutral or positive pressure applications and intended for use in a variety of applications including, but not limited to, Special Gas Vent for Category II, III and IV.

ASSEMBLY AND CONSTRUCTION

PowerStack components have a male-to-female joint system with an integrated Elastomer Triple Lip Seal. The installation orientation is female end points downstream. Flow direction is indicated by an arrow on the product label.

When assembling two parts together, the joint will overlap 1.96" (50mm). Effective length is nominal length minus 1.96" (50mm).



The Powerstack assembly showing the glossy liner and the snap-locked Locking Band (LB).

A NICE AND FINISHED LOOK!

SUPPORT DATA

PRODUCT DATA

SIZE Inch (mm)	PIPE WEIGHT lbs/ft (kg/m)
	EPSC+
4 (100)	2.96 (4.4)
5 (130)	3.63 (5.4)
6 (150)	4.05 (6)
7 (180)	4.74 (7.1)
8 (200)	5.20 (7.7)
10 (250)	6.35 (9.4)
12 (300)	7.47 (11.1)
14 (350)	8.52 (12.7)

SIZE Inch (mm)	MAX. HEIGHT ABOVE SUPPORT PLATE ft (m)
	EPSC+
4 (100)	95 (29)
5 (130)	77 (23)
6 (150)	69 (21)
7 (180)	59 (18)
8 (200)	54 (16)
10 (250)	44 (13)
12 (300)	37 (11)
14 (350)	33 (10)

SIZE Inch (mm)	MAX. HOR./VERT. GUIDE SPACING ft (m)
	EPSC
4-14 (100-350)	8.2 (2.5)

SIZE Inch (mm)	MAX. FREESTANDING ABOVE ROOF SUPPORT ft (m)
	EPSC
4-14 (100-350)	5.0 (1.52)

CLEARANCES TO COMBUSTIBLES FOR SPECIAL GAS VENT

SIZE Inch (mm)	MIN. CLEARANCE TO COMBUSTIBLES in (mm)	
	VERTICAL Enclosed/Unenclosed	VERTICAL Unenclosed
	4-7 (180)	1 (25)
8-12 (200-300)	1 (25)	2 (50)
14 (350)	1 (2)	3 (75)

JOINT ASSEMBLY PARTS

STANDARD LOCKING BAND (LB)

Used for the general assembly of the EPSC+ product. Features a simple sprung toggle locking device for ease of installation.

Provided as standard with Vent component.

Ordered parts includes:

1 standard locking band

SIZE	DIM. A	SIZE	DIM. A
4 (100)	3.98 (101)	8 (200)	7.91 (201)
5 (130)	5.16 (131)	10 (250)	9.88 (251)
6 (150)	5.94 (151)	12 (30)	11.85 (301)
7 (180)	7.13 (181)	14 (350)	13.78 (350)

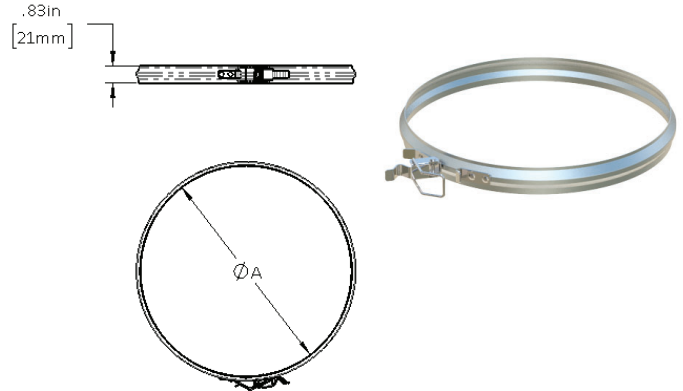

HD LOCKING BAND (TLB)

Used mainly where additional bracing and strength is required at the joint, such as when installing offsets etc.

Ordered parts includes:

1 HD locking band

SIZE	DIM. A	SIZE	DIM. A
4 (100)	4.57 (116)	8 (200)	8.58 (218)
5 (130)	5.75 (146)	10 (250)	10.55 (268)
6 (150)	6.54 (166)	12 (300)	12.52 (318)
7 (180)	7.80 (198)	14 (350)	14.49 (368)

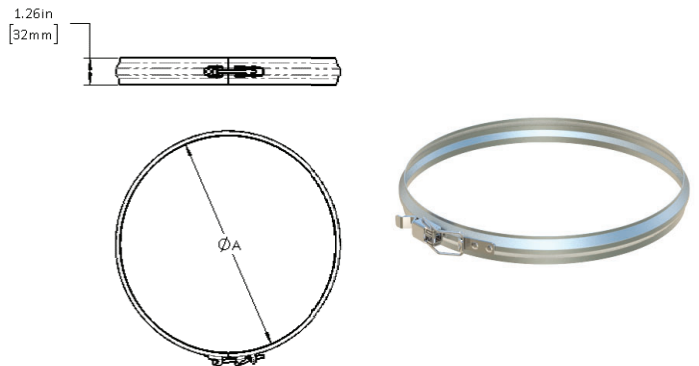

REPLACEMENT GASKET (GG)

The replacement seals are only suitable for use with the EPSC+ product. Please refer to installation instructions on removing and installing replacement seals.

Ordered parts includes:

1 seal

SIZE	DIM. A	SIZE	DIM. A
4 (100)	4.32 (110)	8 (200)	8.26 (210)
5 (130)	5.50 (140)	10 (250)	10.22 (260)
6 (150)	6.29 (160)	12 (30)	12.19 (310)
7 (180)	7.47 (190)	14 (350)	14.16 (360)

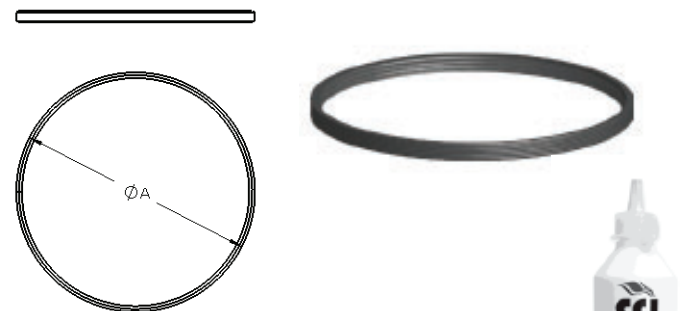

The ENERVEX Seal Lubricant is formulated for use with ENERVEX EPDM and Silicone Seals.

Use of alternative lubricant may invalidate the product warranty and reduce the working life of the seal.



STRAIGHT LENGTHS

STRAIGHT LENGTHS (SL4, SL8, SL18, SL28, SL38, SL48)

Standard lengths for all exhaust systems from 4" to 48". NOTE: Custom lengths available, contact ENERVEX.

Flow Resistance:

K-values (where L = pipe length in feet and D = pipe diameter in inches):

Boiler Vents and Vents $K = 0.30 L/D$

Ordered parts includes:

1 double-wall pipe section with gasket and standard locking band.

NOM. LENGTH	INSTALLED LENGTH 4"-14"
4 (100)	3.86 (98)
8 (200)	8.82 (224)
18 (450)	18.66 (474)
28 (710)	28.5 (724)
38 (965)	38.35 (974)
48 (1,200)	44.72 (1137)

SIZE	PIPE ID	PIPE OD
4 (100)	3.94 (100)	5.91 (150)
6 (150)	5.91 (150)	3.94 (100)
8 (200)	7.87 (200)	9.84 (220)

SIZE	PIPE ID	PIPE OD
10 (250)	9.84 (250)	11.81 (300)
12 (300)	11.81 (300)	13.78 (350)
14 (350)	13.78 (350)	15.75 (400)

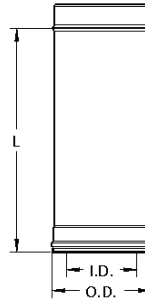

ADJUSTABLE LENGTH (AL)

Field adjustable to fill gaps between standard lengths and to compensate for expansion between two fixed points for applications not to exceed 480°F (250°C) and 15"WC (3700 Pa) of pressure.

Flow Resistance:

Same as for straight lengths

Ordered parts includes:

1 double-wall slip section with gasket and HD locking band.

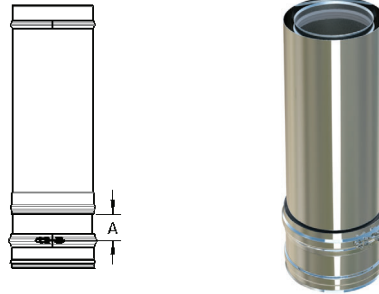

SIZE	ADJUSTABLE LENGTH	
	MIN	MAX
4 (100)	2.48 (63)	11.65 (296)
6 (150)	2.48 (63)	10.67 (271)
8 (200)	2.48 (63)	9.17 (233)
10 (250)	2.48 (63)	8.19 (208)
12 (300)	2.48 (63)	7.20 (183)
14 (350)	2.48 (63)	6.22 (158)

DRAIN SECTION (DS)

Used in horizontal sections when drainage is needed.

Fitted with a 1" (25mm) N.P.T. nipple.

Flow Resistance:

K-value = 0.25

Ordered parts includes:

1 drain section with gasket and standard locking band.

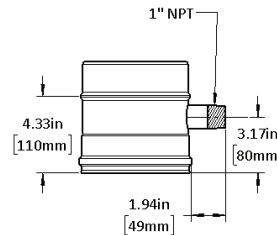

	EPSC+
Installed Length - A	4.33 (110)

TAPERED INCREASER (TI)

Used when a pipe diameter change is required. A tapered section reduces flow resistance over a step version.

Flow Resistance:

$$K = N (1 - (A / B)^2)^2,$$

where A = starting diameter, B = ending diameter, N = 0.47

Ordered parts includes:

When ordering, specify starting diameter first.

1 double-wall pipe section with gasket and standard locking band.

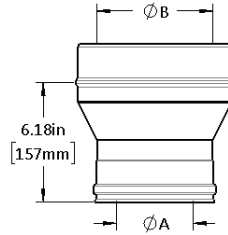

DIAMETER	DIMENSION	
	A	B
4 x 6	3.94 (100)	5.91 (150)
6 x 8	5.91 (150)	7.87 (200)
8 x 10	7.87 (200)	9.84 (250)
8 x 12	7.87 (200)	11.81 (300)

DIAMETER	DIMENSION	
	A	B
10 x 12	9.84 (250)	11.81 (300)
10 x 14	9.84 (250)	13.78 (350)
12 x 14	11.81 (300)	13.78 (350)

TAPERED REDUCER (TR)

Used when a pipe diameter change is required. A tapered reduces flow resistance over a step version.

Flow Resistance:

$$K = N (1 - (A / B)^2)^2,$$

where A = starting diameter, B = ending diameter, N = 0.47

Ordered parts includes:

When ordering, specify starting diameter first.

1 double-wall pipe section with gasket and standard locking band.

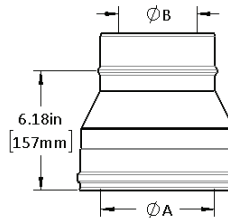

DIAMETER	DIMENSION	
	A	B
6 x 4	5.91 (150)	3.94 (100)
8 x 6	7.87 (200)	5.91 (150)
10 x 8	9.84 (250)	7.87 (200)
12 x 8	11.81 (300)	7.87 (200)

DIAMETER	DIMENSION	
	A	B
12 x 10	11.81 (300)	9.84 (250)
14 x 10	13.78 (350)	9.84 (250)
14 x 12	13.78 (350)	11.81 (300)

ECENTRIC TAPERED INCREASER (ETI)

Used to ease condensate run off in horizontal installations when a pipe diameter change is required.

Flow Resistance:

$$K = N (1 - (A / B)^2)^2,$$

where A = starting diameter, B = ending diameter, N = 0.53

Ordered parts includes:

When ordering, specify upstream diameter first.

1 double-wall pipe section with gasket and standard locking band.

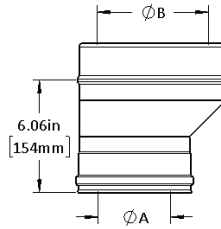

DIAMETER	DIMENSION		DIAMETER	DIMENSION	
	A	B		A	B
4 x 6	3.94 (100)	5.91 (150)	8 x 12	7.87 (200)	11.81 (300)
4 x 8	3.94 (100)	7.87 (200)	10 x 12	9.84 (250)	11.81 (300)
6 x 8	5.91 (150)	7.87 (200)	10 x 14	9.84 (250)	13.78 (350)
6 x 10	5.91 (150)	9.84 (250)	12 x 14	11.81 (300)	13.78 (350)
8 x 10	7.87 (200)	9.84 (250)			

ECENTRIC TAPERED REDUCER (ETR)

Used to ease condensate run off in horizontal installations when a pipe diameter change is required.

Flow Resistance:

$$K = N (1 - (A / B)^2)^2,$$

where A = starting diameter, B = ending diameter, N = 0.53

Ordered parts includes:

When ordering, specify upstream diameter first.

1 double-wall pipe section with gasket and standard locking band.

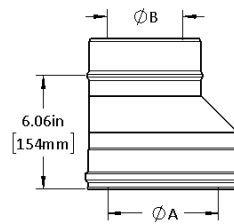

DIAMETER	DIMENSION		DIAMETER	DIMENSION	
	A	B		A	B
6 x 4	5.91 (150)	3.94 (100)	12 x 8	11.81 (300)	7.87 (200)
8 x 4	7.87 (200)	3.94 (100)	12 x 10	11.81 (300)	9.84 (250)
8 x 6	7.87 (200)	5.91 (150)	14 x 10	9.84 (250)	9.84 (250)
10 x 6	9.84 (250)		14 x 12	9.84 (250)	11.81 (300)
10 x 8	9.84 (250)	7.87 (200)			

FITTINGS

90° / 87° TEE (T90 / T87)

Designed to provide a connection, a change of direction and cleaning access, if required.

Flow Resistance:

$K = 1.25$

Ordered parts includes:

1 Tee with gaskets and standard locking bands

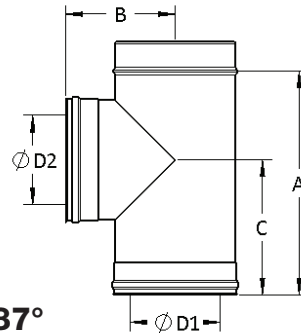

90°

87°

DIA	DIMENSION				
	A	B	C	D1	D2
4 x 4	12.80 (325)	6.22 (158)	7.91 (201)	3.94 (100)	3.94 (100)
6 x 4	10.16 (258)	6.93 (176)	6.02 (153)	5.91 (150)	3.94 (100)
6 x 6	14.76 (375)	7.20 (183)	8.90 (226)	5.91 (150)	5.91 (150)
8 x 4	10.16 (258)	7.91 (201)	5.97 (152)	7.87 (200)	3.94 (100)
8 x 6	12.13 (308)	7.91 (201)	6.97 (177)	7.87 (200)	5.91 (150)
8 x 8	16.81 (427)	8.27 (210)	9.96 (253)	7.87 (200)	7.87 (200)
10 x 4	10.16 (258)	8.90 (226)	5.98 (152)	9.94 (250)	3.94 (100)
10 x 6	12.13 (308)	8.90 (226)	6.97 (177)	9.94 (250)	5.91 (150)
10 x 8	14.09 (358)	8.90 (226)	7.95 (202)	9.94 (250)	7.87 (200)
10 x 10	18.78 (477)	9.25 (235)	10.94 (278)	9.94 (250)	9.94 (250)
12 x 4	10.16 (258)	9.88 (251)	5.97 (152)	11.81 (300)	3.94 (100)
12 x 6	12.13 (308)	9.88 (251)	6.97 (177)	11.81 (300)	5.91 (150)
12 x 8	14.09 (358)	9.88 (251)	7.95 (202)	11.81 (300)	7.87 (200)
12 x 10	16.06 (408)	9.88 (251)	8.94 (227)	11.81 (300)	9.94 (250)
12 x 12	20.63 (524)	10.16 (258)	11.22 (285)	11.81 (300)	11.81 (300)
14 x 4	10.16 (258)	10.87 (276)	5.97 (152)	13.78 (350)	3.94 (100)
14 x 6	12.13 (308)	10.87 (276)	6.97 (177)	13.78 (350)	5.91 (150)
14 x 8	14.09 (358)	10.87 (276)	7.95 (202)	13.78 (350)	7.87 (200)
14 x 10	16.06 (408)	10.87 (276)	8.94 (227)	13.78 (350)	9.94 (250)
14 x 12	20.63 (524)	10.87 (276)	9.92 (252)	13.78 (350)	11.81 (300)
14 x 14	22.60 (574)	11.14 (283)	12.80 (325)	13.78 (350)	13.78 (350)

DIA	DIMENSION				
	A	B	C	D1	D2
4 x 4	11.22 (285)	5.83 (148)	7.13 (181)	3.94 (100)	3.94 (100)
6 x 4	9.37 (238)	6.81 (173)	6.02 (153)	5.91 (150)	3.94 (100)
6 x 6	13.19 (335)	6.81 (173)	8.11 (206)	5.91 (150)	5.91 (150)
8 x 4	9.37 (238)	7.87 (200)	5.98 (152)	7.87 (200)	3.94 (100)
8 x 6	11.34 (288)	7.87 (200)	6.97 (177)	7.87 (200)	5.91 (150)
8 x 8	15.24 (387)	7.87 (200)	9.17 (233)	7.87 (200)	7.87 (200)
10 x 4	9.37 (238)	8.86 (225)	5.98 (152)	9.94 (250)	3.94 (100)
10 x 6	11.34 (288)	8.86 (225)	6.97 (177)	9.94 (250)	5.91 (150)
10 x 8	13.31 (338)	8.86 (225)	7.95 (202)	9.94 (250)	7.87 (200)
10 x 10	17.20 (437)	8.86 (225)	10.16 (258)	9.94 (250)	9.94 (250)
12 x 4	9.37 (238)	9.76 (248)	5.97 (152)	11.81 (300)	3.94 (100)
12 x 6	11.34 (288)	9.76 (248)	6.97 (177)	11.81 (300)	5.91 (150)
12 x 8	13.31 (338)	9.76 (248)	7.95 (202)	11.81 (300)	7.87 (200)
12 x 10	15.28 (388)	9.76 (248)	8.94 (227)	11.81 (300)	9.94 (250)
12 x 12	19.06 (484)	9.76 (248)	10.43 (265)	11.81 (300)	11.81 (300)
14 x 4	9.37 (238)	10.75 (273)	5.97 (152)	13.78 (350)	3.94 (100)
14 x 6	11.34 (288)	10.75 (273)	6.97 (177)	13.78 (350)	5.91 (150)
14 x 8	13.31 (338)	10.75 (273)	7.95 (202)	13.78 (350)	7.87 (200)
14 x 10	15.28 (388)	10.75 (273)	8.94 (227)	13.78 (350)	9.94 (250)
14 x 12	17.24 (438)	10.75 (273)	9.92 (252)	13.78 (350)	11.81 (300)
14 x 14	21.05 (534)	10.75 (273)	12.01 (305)	13.78 (350)	13.78 (350)

45° LATERAL TEE (T45)

Used at the base of a vertical Vent, or for horizontal header configurations where a smooth transition is required. Can also be used as a drainage component when used with the Drain Tee Cap (DTC).

Flow Resistance:

$K = 0.4$

Ordered parts includes:

1 Tee with gaskets and standard locking bands

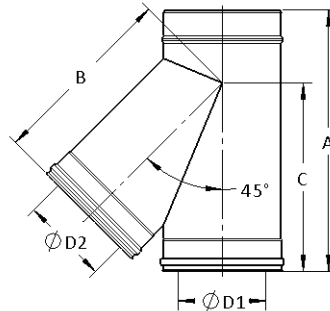

DIA	DIMENSION				
	A	B	C	D1	D2
4 x 4	14.78 (376)	10.35 (263)	10.35 (263)	3.94 (100)	3.94 (100)
6 x 4	17.62 (448)	12.72 (323)	12.72 (323)	5.91 (150)	3.94 (100)
6 x 6	17.62 (448)	12.72 (323)	12.72 (323)	5.91 (150)	5.91 (150)
8 x 4	20.77 (528)	15.12 (384)	15.12 (384)	7.87 (200)	3.94 (100)
8 x 6	20.77 (528)	15.12 (384)	15.12 (384)	7.87 (200)	5.91 (150)
8 x 8	20.77 (528)	15.12 (384)	15.12 (384)	7.87 (200)	7.87 (200)
10 x 4	23.13 (588)	17.48 (444)	17.48 (444)	9.84 (250)	3.94 (100)
10 x 6	23.13 (588)	17.48 (444)	17.48 (444)	9.84 (250)	5.91 (150)
10 x 8	23.13 (588)	17.48 (444)	17.48 (444)	9.84 (250)	7.87 (200)
10 x 10	23.13 (588)	17.48 (444)	17.48 (444)	9.84 (250)	9.84 (250)

DIA	DIMENSION				
	A	B	C	D1	D2
12 x 4	25.93 (659)	19.80 (503)	19.80 (503)	11.81 (300)	3.94 (100)
12 x 6	25.93 (659)	19.80 (503)	19.80 (503)	11.81 (300)	5.91 (150)
12 x 8	25.93 (659)	19.80 (503)	19.80 (503)	11.81 (300)	7.87 (200)
12 x 10	25.93 (659)	19.80 (503)	19.80 (503)	11.81 (300)	9.84 (250)
12 x 12	25.93 (659)	19.80 (503)	19.80 (503)	11.81 (300)	11.81 (300)
14 x 4	28.72 (730)	22.24 (565)	22.24 (565)	13.78 (350)	3.94 (100)
14 x 6	28.72 (730)	22.24 (565)	22.24 (565)	13.78 (350)	5.91 (150)
14 x 8	28.72 (730)	22.24 (565)	22.24 (565)	13.78 (350)	7.87 (200)
14 x 10	28.72 (730)	22.24 (565)	22.24 (565)	13.78 (350)	9.84 (250)
14 x 12	28.72 (730)	22.24 (565)	22.24 (565)	13.78 (350)	11.81 (300)
14 x 14	28.72 (730)	22.24 (565)	22.24 (565)	13.78 (350)	13.78 (350)

90° / 87° ELBOW (L90 / L87)

Designed to provide a 90° or 87° horizontal or vertical change of direction. The 87° elbow is typically used in condensing applications, to create a 3° slope.

Flow Resistance:

$K = 0.3$

Ordered parts includes:

1 elbow with gasket and standard locking band.

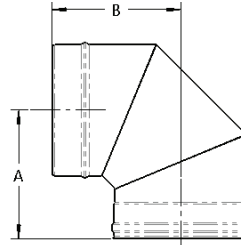

SIZE	EPSC+ 90°	
	A	B
4 (100)	6.77 (172)	4.80 (122)
6 (150)	7.76 (197)	5.79 (147)
8 (200)	8.74 (222)	6.73 (197)
10 (250)	9.72 (247)	7.76 (197)
12 (300)	10.75 (273)	8.78 (223)
14 (350)	11.73 (298)	9.76 (248)

SIZE	EPSC+ 87°	
	A	B
4 (100)	7.32 (186)	5.04 (128)
6 (150)	8.35 (212)	6.02 (153)
8 (200)	9.29 (236)	6.97 (177)
10 (250)	10.28 (261)	7.91 (201)
12 (300)	11.18 (284)	8.86 (225)
14 (350)	12.17 (309)	9.76 (248)

45° / 42° ELBOW (L45 / L42)

Designed to provide a 45° or 42° horizontal or vertical change of direction. Can be used to create a 45° or 42° offset by using two fittings.

Flow Resistance:

$K = 0.15$

Ordered parts includes:

1 elbow with gasket and standard locking band.

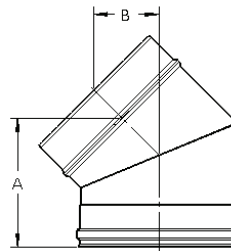

SIZE	EPSC+ 45°	
	A	B
4 (100)	5.87 (149)	2.99 (76)
6 (150)	6.54 (166)	3.27 (83)
8 (200)	7.20 (183)	3.58 (91)
10 (250)	7.95 (202)	3.86 (98)
12 (300)	8.66 (220)	4.17 (106)
14 (350)	9.37 (238)	4.45 (113)

SIZE	EPSC+ 42°	
	A	B
4 (100)	5.75 (146)	2.80 (71)
6 (150)	6.42 (163)	3.03 (77)
8 (200)	7.17 (182)	3.31 (84)
10 (250)	7.87 (200)	3.58 (91)
12 (300)	8.46 (215)	3.78 (96)
14 (350)	9.13 (232)	4.06 (103)

30° ELBOW (L30)

Designed to provide a 30° horizontal or vertical change of direction.
Can be used to create a 30° offset by using two fittings.

Flow Resistance:

$K = 0.15$

Ordered parts includes:

1 elbow with gasket and standard locking band.

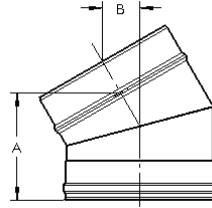

SIZE	EPSC+	
	A	B
4 (100)	5.39 (137)	1.93 (49)
6 (150)	5.83 (148)	2.05 (52)
8 (200)	6.34 (161)	2.17 (53)
10 (250)	6.85 (174)	2.28 (58)
12 (300)	8.03 (204)	2.60 (66)
14 (350)	8.54 (217)	2.76 (70)

15° ELBOW (L15)

Designed to provide a 15° horizontal or vertical change of direction.
Can be used to create a 15° offset by using two fittings.

Flow Resistance:

$K = 0.06$

Ordered parts includes:

1 elbow with gasket and standard locking band.

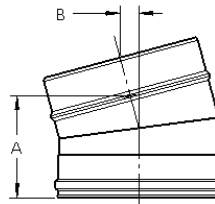

SIZE	EPSC+	
	A	B
4 (100)	4.80 (122)	0.91 (23)
6 (150)	5.08 (129)	0.94 (24)
8 (200)	5.28 (134)	0.98 (25)
10 (250)	5.55 (141)	0.98 (25)
12 (300)	6.57 (167)	1.10 (28)
14 (350)	6.85 (174)	1.18 (30)

6° ELBOW (L6)

Designed to provide a 6° horizontal change of direction or a 6° slope in condensing applications.

NOTE: Available with integrated drain making it suitable for installation in long horizontal runs where can provide sectional drainage without increasing overall slope. Add "T" to the item number.

Flow Resistance:

$K = 0.01$

Ordered parts includes:

1 elbow with gasket and standard locking band.

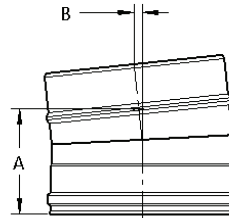

SIZE	EPSC+ 6°	
	A	B
4 (100)	4.37 (111)	0.31 (8)
6 (150)	4.65 (118)	0.35 (9)
8 (200)	4.88 (124)	0.35 (9)
10 (250)	5.16 (131)	0.39 (10)
12 (300)	6.14 (156)	0.43 (11)
14 (350)	6.42 (163)	0.43 (11)

3° ELBOW (L3)

Designed to provide a 3° horizontal change of direction or a 3° slope in condensing applications.

NOTE: Available with integrated drain making it suitable for installation in long horizontal runs where can provide sectional drainage without increasing overall slope. Add "T" to the item number.

Flow Resistance:

$K = 0.01$

Ordered parts includes:

1 elbow with gasket and standard locking band.

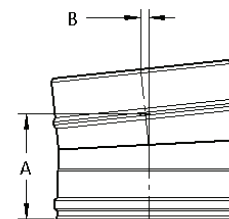

SIZE	EPSC+ 6°	
	A	B
4 (100)	4.25 (108)	0.16 (4)
6 (150)	4.53 (115)	0.16 (4)
8 (200)	4.76 (121)	0.16 (4)
10 (250)	5.04 (128)	0.20 (5)
12 (300)	6.06 (154)	0.20 (5)
14 (350)	6.34 (161)	0.24 (6)

DRAIN TEE CAP (DTC)

Provides a drain at the base of a vertical Vent when connected to a 90° Tee (T90) or 45° Lateral Tee (T45). Includes a 1" N.P.T. (4"-24") or 2" N.P.T. (26"-48") Nipple.

Ordered parts includes:

1 drain tee cap with gasket and standard locking band.

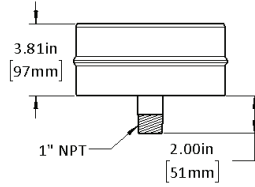

	EPSC+
Installed Length - A (not including nipple)	3.81 (97)
Nipple Length	2.00 (51)

SIDE DRAIN TEE CAP (DTCS)

Provides a drain at the base of a vertical Vent when connected to a 90° Tee (T90) or 45° Lateral Tee (T45).

Ordered parts includes:

1 drain tee cap with gasket

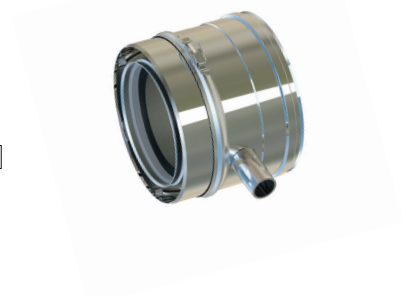
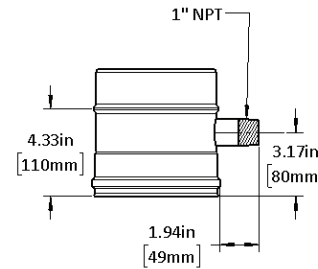

	EPSC+
Installed Length - A (not including nipple)	5.27 (134)
Nipple Length	2.08 (53)

TEE CAP (TC)

Provides for cleanout at the end of a manifold when connected to a 90° Tee (T90) or a 45° Lateral Tee (T45).

Ordered parts includes:

1 tee cap with gasket

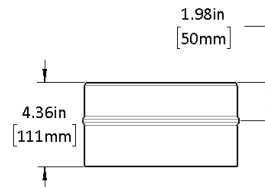

	EPSC+
Installed Length - A	4.36 (111)

CONNECTIONS

(PLEASE INQUIRE ABOUT CONNECTORS FOR SPECIFIC APPLIANCE MODELS)

UNIVERSAL BOILER ADAPTER (UBA)

Designed to connect to a boiler or other with a flanged outlet with a 4, 6, 8 or 12 hole pattern. Specify hole pattern and dimensions at order entry

Flow Resistance:

K = 0

Ordered parts includes:

1 universal boiler adapter

Ordered separately:

1 double-wall pipe section with gasket

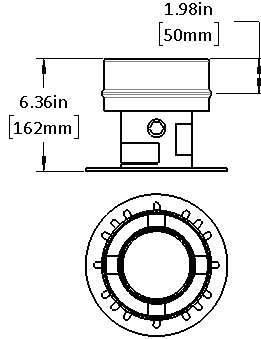

	EPSC+
Installed Length - A	6.36 (162)

APPLIANCE CONNECTOR SEAL RING (ACS)

Used for non-welded attachment to appliances without a flanged outlet or with a collar outlet.

Ordered parts includes:

1 appliance connector seal ring

SIZE	ID
4 (100)	4.00 (102)
6 (150)	6.00 (152)
8 (200)	8.00 (203)
10 (250)	10.00 (254)
12 (300)	12.00 (305)
14 (350)	14.00 (356)

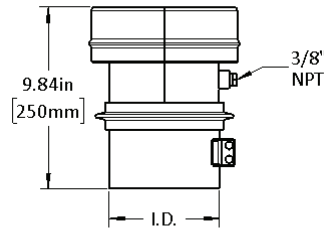

TERMINATIONS

RAIN CAP (RC)

Provides partial protection with low flow resistance. May require a Drain Tee Cap (DTC) at the base of stack.

Flow Resistance:

$K = 0.5$

Ordered parts includes:

1 double-wall pipe section with gasket and standard locking band.

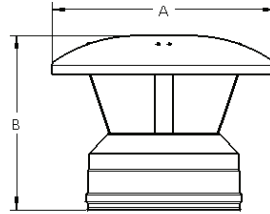

SIZE	EPSC+	
	A	B
4 (100)	7.20 (183)	8.07 (205)
6 (150)	11.89 (302)	9.29 (236)
8 (200)	15.94 (405)	11.26 (286)
10 (250)	18.82 (478)	11.81 (300)
12 (300)	23.66 (601)	14.13 (359)
14 (350)	28.35 (720)	17.52 (445)

EXIT CONE (EXC)

The exit cone offers minimal resistance to the evacuation of flue gases and helps to minimise the effects of plumbing by slightly increasing the exit velocity.

Flow Resistance:

$K = \sim 0$

Ordered parts includes:

1 double-wall pipe section with gasket and standard locking band.

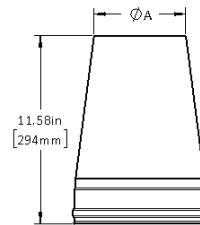

SIZE	EPSC+
	A
4 (100)	3.54 (90)
6 (150)	5.51 (140)
8 (200)	7.48 (190)
10 (250)	9.45 (240)
12 (300)	11.42 (290)
14 (350)	13.39 (340)

MITER SECTION (MS)

Used for horizontal engine and generator exhaust when discharging horizontally. Can also be used with a 90° elbow (L90) for vertical Vent termination.

Flow Resistance:

$K = \sim 0$

Ordered parts includes:

1 miter section with gasket and standard locking band.

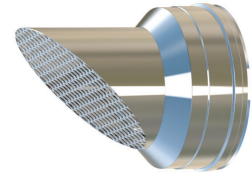
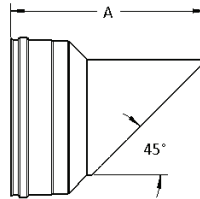

SIZE	EPSC+ A
4 (100)	8.19 (208)
6 (150)	10.16 (258)
8 (200)	12.13 (308)
10 (250)	14.09 (358)
12 (300)	16.06 (408)
14 (350)	18.03 (458)

WALL TERMINAL (WT)

An exit cap for use where EPSC+ serves conventional gas fired equipment. Incorporates a bird screen/mesh. For condensing and positive pressure applications,

Flow Resistance:

$K = \sim 0$

Ordered parts includes:

1 wall terminal section with gasket and standard locking band.

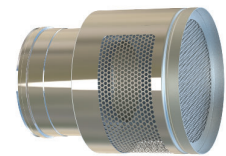
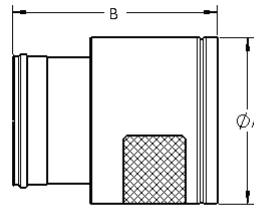

SIZE	EPSC+	
	A	B
4 (100)	8.27 (210)	12.80 (325)
6 (150)	10.43 (265)	12.80 (325)
8 (200)	13.19 (355)	13.58 (345)
10 (250)	16.14 (410)	13.58 (345)
12 (300)	19.09 (485)	13.58 (345)
14 (350)	22.05 (560)	13.58 (345)

SUPPORTS

SUPPORT PLATE ASSEMBLY (SPA)

Used for supporting the load of a stack and as a fixing point anchor near fittings. Can be used with any straight length.

Ordered parts includes:

1 single, flange plate and two half-plates and hardware

THE ASSEMBLY MUST BE MOUNTED ON ALL FOUR SIDES TO A STRUCTURAL FRAME AND ATTACHED TO THE BUILDING STRUCTURE.

Installed Length: 7.8" (198mm)

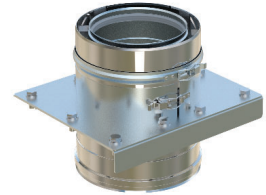
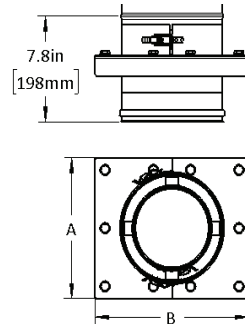

SIZE	EPSC+	
	A	B
4 (100)	8.43 (214)	10.24 (260)
6 (150)	10.39 (264)	12.20 (310)
8 (200)	12.36 (314)	14.17 (360)
10 (250)	14.33 (364)	16.14 (410)
12 (300)	16.30 (414)	18.11 (460)
14 (350)	18.27 (464)	20.08 (510)

WALL SUPPORT ASSEMBLY (WSA)

Use with straight lengths to partly support the load of a vertical Vent system with factory supplied bracing. Assembly will maintain a 2" clearance between pipe OD and supporting structure. Note: Cannot be attached to combustible surface/structure

Installed height = 6

Ordered parts includes:

1 single (flanged) plate and two half-plates

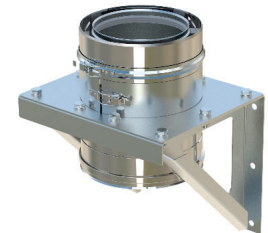
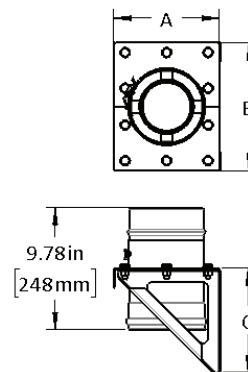

SIZE	A	B	C
	4 (100)	8.19 (208)	10.24 (260)
6 (150)	10.47 (266)	12.20 (310)	10.31 (262)
8 (200)	12.28 (312)	14.17 (360)	12.20 (310)
10 (250)	14.41 (366)	16.14 (410)	14.29 (363)
12 (300)	16.42 (417)	18.11 (460)	16.26 (413)
14 (350)	18.35 (466)	20.08 (510)	18.27 (464)

WALL GUIDE (WG)

Used for guiding vertical installation. Uses a Full Ring (FR) with factory-supplied bracing. Assembly will maintain a 2" clearance between pipe OD and supporting structure. Note: Cannot be used on combustible surface/structure

Ordered parts includes:

2 cradles and bracket

PLEASE NOTE THAT SIZES ARE BASED ON THE OUTER DIAMETER OF THE VENT, AND NOT THE INNER DIAMETER AS USED FOR OTHER PARTS

SIZE	EPSC+		SIZE	A	B
	A	B			
4 (100)	2.78 (71)	4.02 (102)	8 (300)	6.38 (162)	7.95 (202)
6 (150)	3.62 (92)	5.20 (132)	10 (400)	8.35 (212)	9.92 (252)
6 (200)	4.41 (112)	5.98 (152)	12 (450)	10.47 (266)	11.89 (302)
7 (250)	5.59 (142)	7.17 (182)	14 (500)	12.44 (316)	13.86 (352)

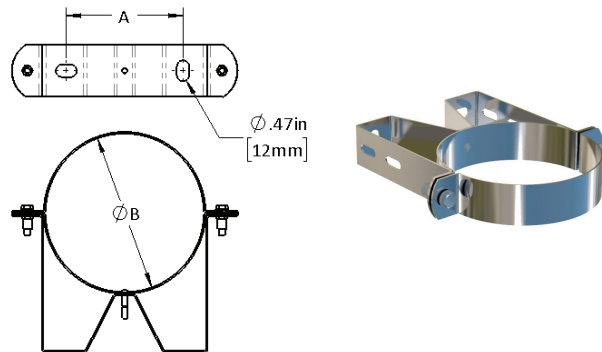

FLOOR GUIDE (FG)

Used for guiding vertical installation through floors. Uses a Full-Angle Ring (FR) with factory-supplied bracing for use on floor level.

Ordered parts includes:

1 floor guide
1 hardware

PLEASE NOTE THAT SIZES ARE BASED ON THE OUTER DIAMETER OF THE Vent, AND NOT THE INNER DIAMETER AS USED FOR OTHER PARTS.

SIZE	ID	A	B
4 (100)	4.12 (105)	27.09 (688)	6.57 (167)
5 (130)	5.31 (135)	27.09 (688)	7.56 (192)
6 (150)	6.10 (155)	27.09 (688)	8.54 (217)
7 (180)	7.28 (185)	27.09 (688)	9.53 (242)

SIZE OD	ID	A	B
8 (200)	8.07 (205)	27.09 (688)	10.51 (267)
10 (250)	10.04 (255)	27.09 (688)	12.48 (317)
12 (300)	12.01 (305)	27.09 (688)	14.45 (367)
14 (350)	13.98 (355)	27.09 (688)	16.42 (417)

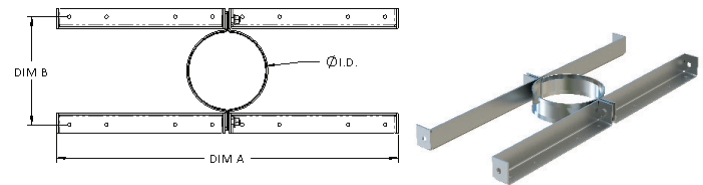

FULL RING (FR)

Used for guiding and/or supporting horizontal installations. Can be used as full ring or cradle (half ring)

Ordered parts includes:

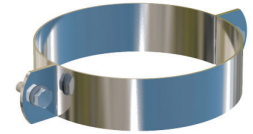
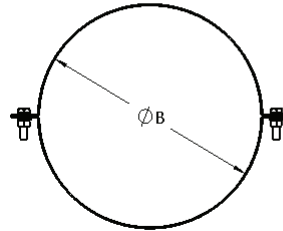
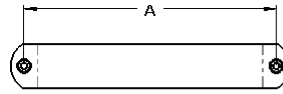

SIZE	A	B	SIZE	A	B
4 (100)	5.39 (1.37)	4.02 (102)	8 (200)	9.33 (237)	7.95 (202)
5 (130)	6.57 (167)	5.20 (132)	10 (250)	11.30 (287)	9.92 (232)
6 (150)	7.36 (187)	5.98 (152)	12 (300)	13.27 (337)	11.89 (302)
7 (180)	8.54 (217)	7.17 (182)	14 (350)	15.24 (387)	13.86 (352)

GUY SECTION ASSEMBLY (GSA)

A rigid, factory welded section for attaching guys to the Vent stack

Ordered parts includes:

Guy Section with gasket and standard locking band.

Installed Length (all sizes): 8.23" (209mm)

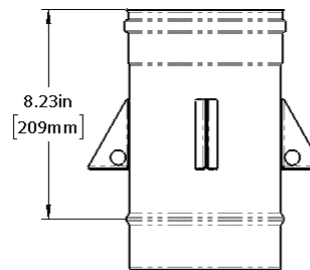

PENETRATIONS

ROOF THIMBLE (RT)

Used for a roof penetrations to eliminate clearance to combustibles. Consists of a roof thimble section clamped around the vent.

Ordered parts includes:

1 thimble

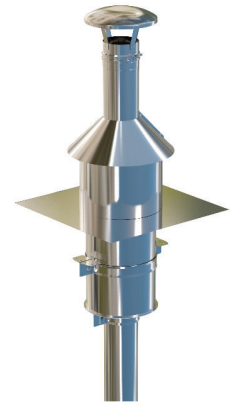
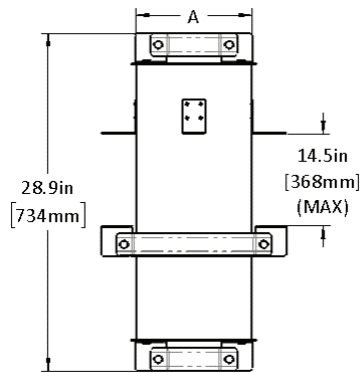

SIZE	A	B	C	SIZE	A	B	C
4 (100)	9.92 (252)	28.90 (734)	14.50 (368)	8 (200)	13.86 (352)	28.90 (734)	14.50 (368)
5 (130)	10.91 (277)	28.90 (734)	14.50 (368)	10 (250)	15.83 (402)	28.90 (734)	14.50 (368)
6 (150)	11.89 (302)	28.90 (734)	14.50 (368)	12 (300)	17.80 (452)	28.90 (734)	14.50 (368)
7 (180)	12.87 (327)	28.90 (734)	14.50 (368)	14 (350)	19.76 (502)	28.90 (734)	14.50 (368)

WALL THIMBLE (WT)

Used when pipe passes through a combustible wall structure to eliminate clearance to combustibles. The thimble allows for pipe expansion and contraction through the wall.

Ordered parts includes:

1 thimble

Ordered separately:

1 Flashing (FL)

1 Storm Collar (SC)

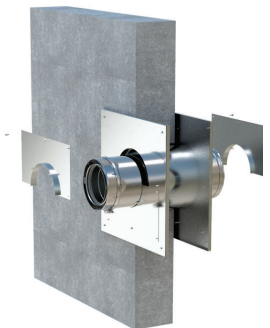
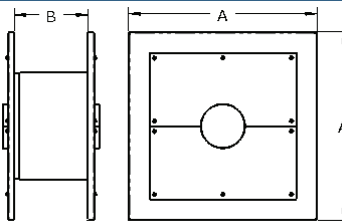

SIZE	A	B		SIZE	A	B	
		MIN	MAX			MIN	MAX
4 (100)	17.87 (454)	6.00 (152)	11.00 (279)	8 (200)	21.81 (554)	6.00 (152)	11.00 (279)
5 (130)	19.06 (484)	6.00 (152)	11.00 (279)	10 (250)	23.78 (604)	6.00 (152)	11.00 (279)
6 (150)	19.84 (504)	6.00 (152)	11.00 (279)	12 (300)	25.75 (654)	6.00 (152)	11.00 (279)
7 (180)	21.02 (534)	6.00 (152)	11.00 (279)	14 (350)	27.71 (704)	6.04 (153)	11.04 (280)

FLASHINGS (FL, F35, F45)

Used in conjunction with a storm collar for weatherization of the roof

Ordered parts includes:

1 flashing

Ordered separately:

1 Storm Collar (SC) - make sure to use size equal to pipe OD + 4".

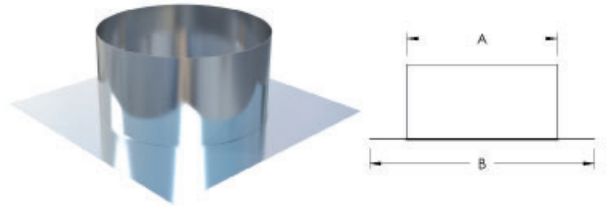

ID SIZE	ALL		
	A	B	C
4 (100)	5.12 (130)	7.87 (200)	11.81 (200)
5 (130)	5.71 (145)	8.86 (225)	11.81 (200)
6 (150)	6.30 (160)	9.84 (250)	11.81 (200)
7 (180)	7.28 (185)	10.83 (275)	11.81 (200)

ID SIZE	ALL		
	A	B	C
8 (200)	8.27 (210)	11.81 (300)	11.81 (200)
10 (250)	10.24 (260)	13.78 (350)	11.81 (200)
12 (300)	12.20 (310)	15.75 (400)	11.81 (200)
14 (350)	14.17 (360)	17.72 (450)	11.81 (200)

TELESCOPIC FLASHING (TFL)

This component weatherproofs the Powerstack's passage through the roof and must be used where the expansion of the Vent is calculated to exceed 4" (100mm).

It is also used to weaterproof passage through a wall when an Insulated Wall Thimble (IT) is used

Ordered parts includes:

1 flashing

Ordered separately:

1 Storm Collar (SC) - make sure to use size equal to pipe OD + 4".

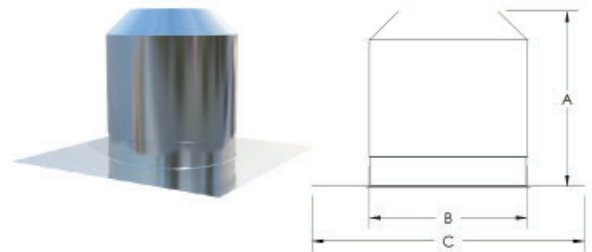

ID SIZE	ALL		
	A	B	C
4 (100)	5.12 (130)	7.87 (200)	11.81 (200)
5 (130)	5.71 (145)	8.86 (225)	11.81 (200)
6 (150)	6.30 (160)	9.84 (250)	11.81 (200)
7 (180)	7.28 (185)	10.83 (275)	11.81 (200)

ID SIZE	ALL		
	A	B	C
8 (200)	8.27 (210)	11.81 (300)	11.81 (200)
10 (250)	10.24 (260)	13.78 (350)	11.81 (200)
12 (300)	12.20 (310)	15.75 (400)	11.81 (200)
14 (350)	14.17 (360)	17.72 (450)	11.81 (200)

STORM COLLAR (SC)

Used above a flashing and secured to our jacket for complete weatherization above the roof.

Ordered parts includes:

- 1 storm collar
- 1 installation hardware

Ordered separately:

- 1 Silicone

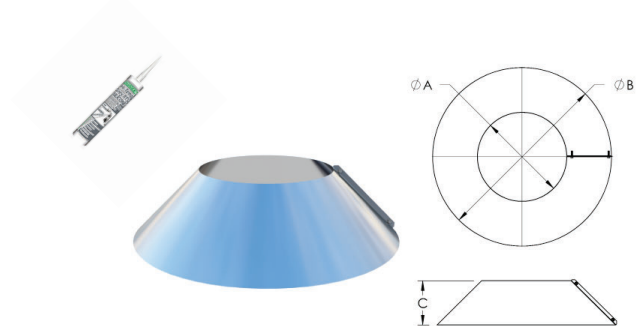

ID SIZE	ALL		
	A	B	C
4 (100)	4.02 (102)	8.07 (205)	2.75 (70)
5 (130)	5.00 (127)	9.06 (230)	2.75 (70)
6 (150)	5.98 (152)	10.04 (255)	2.75 (70)
7 (180)	6.97 (177)	11.02 (280)	2.75 (70)

ID SIZE	ALL		
	A	B	C
8 (200)	7.95 (202)	11.85 (301)	2.75 (70)
10 (250)	9.92 (252)	13.81 (351)	2.75 (70)
12 (300)	11.88 (302)	15.78 (401)	2.75 (70)
14 (350)	13.85 (352)	17.75 (451)	2.75 (70)

FAN PLATE ADAPTER (FPA)

Used for connection to a Vent fan (RSV) termination fan or other termination fan.

Note: Dimension (B) of square plate must be specified when ordering.

Flow Resistance:

$$K = \sim 0$$

Ordered parts includes:

- 1 fan plate adapter and standard locking band

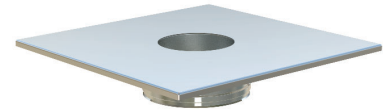
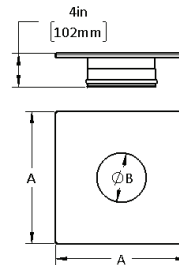

DIAMETER	DIMENSION	
	A	B
4 (Series 2)	12.20 (310)	3.82 (97)
6 (Series 2)	12.20 (310)	5.83 (148)
6 (Series 3)	15.59 (396)	5.83 (148)
6 (Series 4)	19.69 (500)	5.83 (148)
8 (Series 2)	12.20 (310)	7.80 (198)
8 (Series 3)	15.59 (396)	7.80 (198)
8 (Series 4)	19.69 (500)	7.80 (198)
10 (Series 2)	12.20 (310)	9.80 (249)

DIAMETER	DIMENSION	
	A	B
10 (Series 3)	15.59 (396)	9.80 (249)
10 (Series 4)	19.69 (500)	9.80 (249)
12 (Series 2)	15.59 (396)	11.81 (300)
12 (Series 3)	15.59 (396)	11.81 (300)
12 (Series 4)	19.69 (500)	11.81 (300)
14 (Series 3)	19.69 (500)	13.78 (350)
14 (Series 4)	19.69 (500)	13.78 (350)

TRANSITIONS

TRANSITIONS FOR TDF POWER VENTERS - MALE (TTM) / FEMALE (TTF)

A tapered transition used to connect a standard EPSC+ connection to the flange of a TDF Power Venter (TDF). Female EPSC+ TDF transition will include the locking band.

Flow Resistance:

$K = N (1 - (A / B)^2)^2$, where

A = starting diameter, B = ending diameter, N = 0.47

Ordered parts includes:

1 transition with locking band

DIAMETER	DIMENSION		DIAMETER	DIMENSION		DIAMETER	DIMENSION	
	A	B		A	B		A	B
12 x 4	3.94 (100)	11.81 (300)	14 x 12	11.81 (300)	13.78 (350)	20 x 14	13.78 (350)	20.00 (508)
12 x 5	5.12 (130)	11.81 (300)	16 x 6	5.91 (150)	15.75 (400)	24 x 8	7.87 (200)	24.00 (610)
12 x 6	5.91 (150)	11.81 (300)	16 x 7	7.09 (180)	15.75 (400)	24 x 10	9.84 (250)	24.00 (610)
12 x 7	7.09 (180)	11.81 (300)	16 x 8	7.87 (200)	15.75 (400)	24 x 12	11.81 (300)	24.00 (610)
12 x 8	7.87 (200)	11.81 (300)	16 x 10	9.84 (250)	15.75 (400)	24 x 14	13.78 (350)	24.00 (610)
12 x 10	9.84 (250)	11.81 (300)	16 x 12	11.81 (300)		28 x 8	7.87 (200)	28.00 (711)
14 x 6	5.91 (150)	13.78 (350)	16 x 14	13.78 (350)	15.75 (400)	28 x 10	9.84 (250)	28.00 (711)
14 x 7	7.09 (180)	13.78 (350)	20 x 8	7.87 (200)	20.00 (508)	28 x 12	11.81 (300)	28.00 (711)
14 x 8	7.87 (200)	13.78 (350)	20 x 10	9.84 (250)	20.00 (508)	28 x 14	13.78 (350)	28.00 (711)
14 x 10	9.84 (250)	13.78 (350)	20 x 12	11.81 (300)	20.00 (508)			

TRANSITIONS FOR EPSC+ TO EPSX - MALE (TCM) / FEMALE (TCF)

A transition used to connect a standard EPSC+ male or female connection to the flange of an EPSx chimney.

Flow Resistance:

$K = N (1 - (A / B)^2)^2$, where

A = starting diameter, B = ending diameter, N = 0.47

Ordered parts includes:

- 1 transition
- 1 locking band
- 1 graphite gasket
- 1 U-band

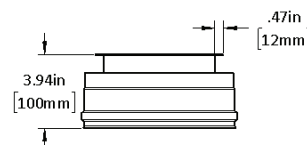
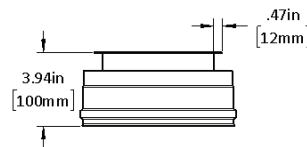

DAMPERS

SEALED MODULATING DAMPER SYSTEM (SMDS)

Single-blade self-sensing, modulating damper and draft control system used to maintain a required pressure (negative or positive) equipped with fast acting actuator. Typically used as a vent-damper and to control the pressure (draft) in a boiler connector. Can be installed vertically or horizontally

MDF damper is UL Listed to UL378 Standard for Draft Equipment and ULC Listed to ULC/ORD-C378 under file number E467733.

Material:

Stainless Steel 316L

Flow Resistance:

Contact Factory

Temperature Rating:

1400°F (760°C)

Ordered parts includes:

- 1 MDF damper with actuator and EBC controller
- 2 U-band (UB)
- 1 Graphite Gasket (GG)
- 1 Two-piece Damper Cover Jacket (DCJ)
- 1 hardware

Ordered separately:

Transitions for EPSC+ to EPSx - Male (TCM) / Female (TCF)

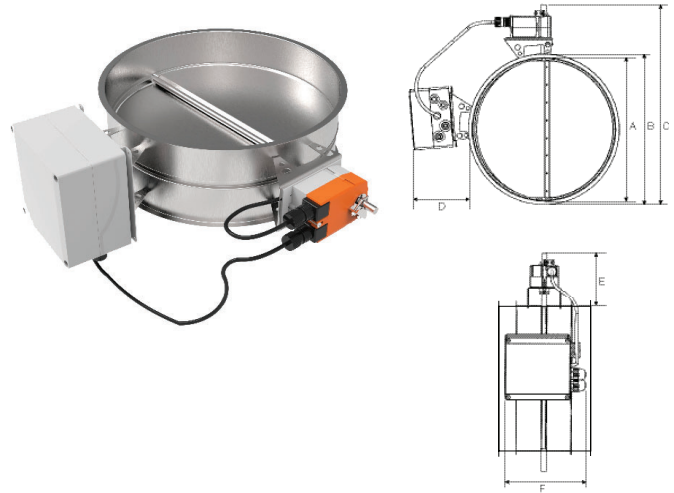

MODEL	DIMENSION			
	A	B	C	D
SDF 4	3.94 (100)	4.88 (124)	8.86 (225)	8.00 (203)
SDF 6	5.91 (150)	6.85 (174)	10.83 (275)	8.00 (203)
SDF 8	7.87 (200)	8.82 (224)	12.80 (325)	8.00 (203)
SDF 10	9.84 (250)	10.79 (274)	14.76 (375)	8.00 (203)
SDF 12	11.81 (300)	12.76 (324)	16.73 (426)	8.00 (203)
SDF 14	13.78 (350)	14.72 (374)	18.70 (475)	8.00 (203)

AUTOMATIC VENT DAMPER (ADF)

Single-blade two position damper equipped with fast acting actuator. Typically used as a vent-damper and to balance the pressure in a boiler connector. Can be installed vertically or horizontally

UL Listed to UL378 Standard for Draft Equipment and ULC Listed to ULC/ORD-C378 under file number E467733.

Material:

Stainless Steel 316L

Flow Resistance:

Contact Factory

Temperature Rating:

1400°F (760°C)

Ordered parts includes:

- 1 damper
- 2 U-band (UB)
- 1 Graphite Gasket (GG)
- 1 hardware

Ordered separately:

Transitions for EPSC+ to EPSx - Male (TCM) / Female (TCF)

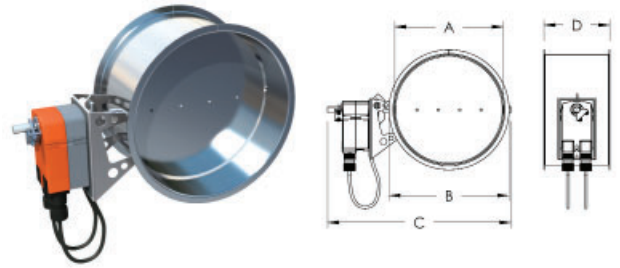

MODEL	DIMENSION			
	A	B	C	D
ADF 6	5.98 (152)	7.01 (178)	11.02 (280)	6.00 (150)
ADF 8	7.99 (203)	9.02 (229)	12.99 (330)	6.00 (150)
ADF 10	10.00 (254)	10.98 (279)	15.00 (381)	6.00 (150)
ADF 12	12.01 (305)	12.99 (330)	17.01 (432)	6.00 (150)
ADF 14	14.02 (356)	15.00 (381)	19.02 (483)	6.00 (150)

BALANCING BAFFLE (BBF)

Single-blade manually operated damper. Typically used to balance the pressure in a boiler connector. Can be installed vertically or horizontally.

UL Listed to UL378 Standard for Draft Equipment and ULC Listed to ULC/ORD-C378 under file number MH61094.

Material:

Stainless Steel 316L

Flow Resistance:

Contact Factory

Temperature Rating:

1400°F (760°C)

Ordered parts includes:

- 1 damper
- 2 U-band (UB)
- 1 Graphite Gasket (GG)
- 1 hardware

Ordered separately:

Transitions for EPSC+ to EPSx - Male (TCM) / Female (TCF)

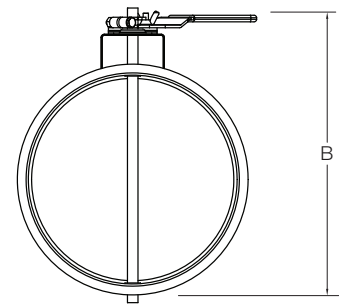
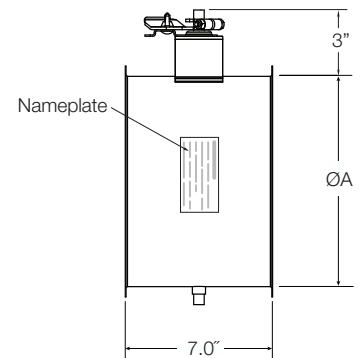

MODEL	DIMENSION			
	A	B	C	D
MDF 6	5.98 (152)	7.01 (178)	11.02 (280)	6.00 (150)
MDF 8	7.99 (203)	9.02 (229)	12.99 (330)	6.00 (150)
MDF 10	10.00 (254)	10.98 (279)	15.00 (381)	6.00 (150)
MDF 12	12.01 (305)	12.99 (330)	17.01 (432)	6.00 (150)
MDF 14	14.02 (356)	15.00 (381)	19.02 (483)	6.00 (150)
MDF 16	15.98 (406)	17.01 (432)	20.98 (533)	6.00 (150)
MDF 18	17.99 (457)	19.02 (483)	22.99 (584)	6.00 (150)
MDF 20	20.00 (508)	20.98 (533)	25.00 (635)	6.00 (150)
MDF 22	22.01 (559)	22.99 (584)	27.01 (686)	6.00 (150)
MDF 24	24.02 (610)	25.00 (635)	29.02 (737)	6.00 (150)

BAROMETRIC DRAFT REGULATOR (BDR)

Single-blade and weighted damper used to stabilize flue draft by drawing room air into the flue. Typically installed in a 90° Tee (T90) and the end of a horizontal breeching. Can only be installed horizontally.

Material:

Stainless Steel 316L

Flow Resistance:

Contact Factory

Temperature Rating:

1400°F (760°C)

Ordered parts includes:

1 barometric damper

1 U-band

1 Graphite Gasket

Ordered separately:

Transitions for EPSC+ to EPSx - Male (TCM) / Female (TCF)

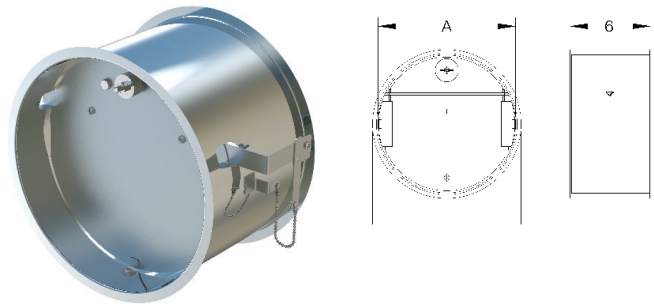

MODEL	DIMENSION			
	A	B	C	D
BDR 6	5.98 (152)	7.01 (178)	11.02 (280)	6.00 (150)
BDR 8	7.99 (203)	9.02 (229)	12.99 (330)	6.00 (150)
BDR 10	10.00 (254)	10.98 (279)	15.00 (381)	6.00 (150)
BDR 12	12.01 (305)	12.99 (330)	17.01 (432)	6.00 (150)
BDR 14	14.02 (356)	15.00 (381)	19.02 (483)	6.00 (150)
BDR 16	15.98 (406)	17.01 (432)	20.98 (533)	6.00 (150)
BDR 18	17.99 (457)	19.02 (483)	22.99 (584)	6.00 (150)
BDR 20	20.00 (508)	20.98 (533)	25.00 (635)	6.00 (150)
BDR 22	22.01 (559)	22.99 (584)	27.01 (686)	6.00 (150)
BDR 24	24.02 (610)	25.00 (635)	29.02 (737)	6.00 (150)

MECHANICAL DRAFT FANS

INLINE POWER VENTER (TDF)

Inline power venter for installation in a vertical or horizontal Vent sections.

Listed to UL378 Standard for Draft Equipment

Material:

Stainless Steel 316L

Temperature Rating:

1400°F (760°C)

Ordered parts includes:

1 TDF fan

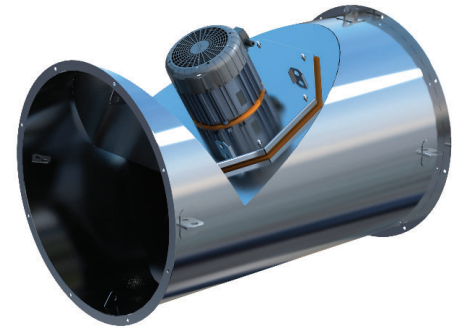
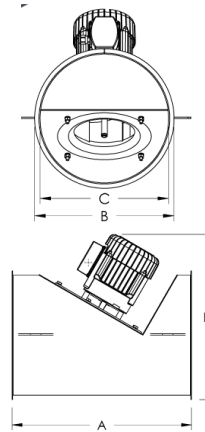

MODEL	DIMENSION				WEIGHT
	A	B	C	D	
TDF 160	18.00 (458)	13.00 (325)	12.00 (300)	14.50 (368)	38 (17)
TDF 200	21.00 (534)	15.00 (375)	14.00 (350)	18.60 (472)	45 (20)
TDF 250	24.00 (610)	17.00 (425)	16.00 (400)	20.00 (508)	61 (28)
TDF 300	27.60 (700)	21.00 (533)	20.00 (508)	22.40 (569)	84 (38)
TDF 400	33.50 (850)	25.00 (635)	24.00 (610)	26.40 (670)	122 (58)
TDF 500	39.40 (1000)	29.00 (736)	28.00 (711)	30.40 (772)	164 (75)

CHIMNEY TERMINATION FAN (RSV)

Termination fan for installation at the end of a chimney.

Listed to UL378 Standard for Draft Equipment.

Material:

Cas aluminum

Temperature Rating:

575°F (300°C) - Continuous

Ordered parts includes:

1 Silicone (HSI)

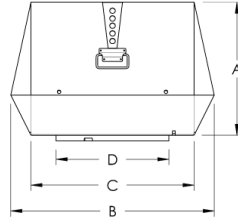

MODEL	DIMENSION				WEIGHT
	A	B	C	D	
RSV 200	11.03 (280)	15.37 (390)	12.22 (310)	7.88 (200)	47 (18)
RSV 250	13.20 (335)	19.11 (485)	15.17 (385)	9.85 (250)	60 (26)
RSV 315	14.97 (380)	22.85 (580)	18.32 (465)	12.41 (315)	88 (35)
RSV 400	16.94 (430)	25.61 (650)	20.69 (525)	15.76 (400)	127 (58)
RSV 450	23.23 (590)	25.61 (650)	20.69 (525)	15.76 (400)	155 (70)

For installation, use Fan Plate Adapter (FA)

WARRANTY

1-YEAR WARRANTY

ENERVEX Inc. ("ENERVEX") warrants the special gas vent system and components against functional failure due to defects in material and workmanship for a period of one year from date of delivery to the construction site. Functional failure is defined as any failure of the system or component to perform its intended function of exhausting, without adverse leakage, combustion by-products from heating equipment. During this period, any system or component supplied by ENERVEX failing to perform its intended function will be repaired or replaced at the manufacturer's option, following determination by a factory-authorized inspector that a functional failure has occurred. This warranty is limited to repair or replacement of the product plus shipping cost to the failure location. This warranty does not cover any labor costs for removal or replacement of the defective product, nor does this warranty cover any system components not furnished by ENERVEX and installed as part of the system.

This limited warranty is non-transferable and extends to the original owner subject to the satisfaction of the following conditions:

- 1) The vent system is inspected and maintained annually, beginning one year after the date of installation and continue throughout the warranty period
- 2) Generally accepted engineering practices have been followed to determine that sizing and material specifications are suitable for the application and environment involved.
- 3) The undamaged components have been correctly installed in accordance with the installation instructions published by ENERVEX at the time of shipment.

Disclaimer:

ENERVEX assumes no liability for incidental or consequential damages of any kind or for any damages resulting in whole or in part from misuse, improper installation, or inadequate maintenance of the system or any component part thereof.

This warranty is in lieu of all other express warranties or guarantees of any kind. All implied warranties, including merchantability and fitness, are limited to the duration of the express warranty contained herein. ENERVEX neither assumes nor does it authorize any other person to assume on its behalf any other liability in connection with the sale of its products.

ANY IMPLIED WARRANTY OF MERCHANTABILITY OR FITNESS FOR A PARTICULAR PURPOSE IS LIMITED IN DURATION TO THE WARRANTY PERIOD SPECIFIED ABOVE. WE DISCLAIM ANY LIABILITY FOR CONSEQUENTIAL OR INCIDENTAL DAMAGES AND ANY LOSS OR EXPENSE(S), NOT SPECIFIED ABOVE. SOME STATES MAY NOT ALLOW THE EXCLUSION OR LIMITATION OF INCIDENTAL OR CONSEQUENTIAL DAMAGES, OR HOW LONG AN IMPLIED WARRANTY LASTS, SO THE ABOVE EXCLUSIONS OR LIMITATIONS MAY NOT APPLY TO YOU. THIS WARRANTY GIVES YOU SPECIFIC LEGAL RIGHTS AND YOU MAY ALSO HAVE LEGAL RIGHTS WHICH VARY FROM STATE TO STATE OR PROVINCE TO PROVINCE.

EXTENDED 15-YEAR WARRANTY

This limited warranty is an extension of the 1-year warranty, is non-transferable and extends to the original owner subject to the satisfaction of these additional conditions:

- 1) System sizing and design has been performed by ENERVEX personnel, and design parameters provided to ENERVEX by the responsible engineer were and are accurately representative of the operating conditions.
- 2) The undamaged components have been correctly installed in accordance with system design and sizing as performed by ENERVEX and installation instructions published by ENERVEX at the time of shipment.
- 3) Proper precautions have been taken to insure that heating equipment combustion air is free of solvent or refrigerant vapors or any halogenated compound which may cause acid condensates to form within the vent.
- 4) Damage is not a result of burning garbage, waste oil, #6 oil or any other prohibitive material in the appliance served by the venting system.
- 5) ENERVEX has supplied the entire chimney or exhaust system from heating equipment outlet to the termination of the vent. The ENERVEX 15&1 Warranty applies to the following products: EPSC and EPSC+ used in Residential and Commercial applications.